

NICHYU

WALKIE HIGH LIFT TRUCKS

SPECIFICATIONS

FBD-70 Series SBW-70 Series



FBD7-70-150

(Single mast)

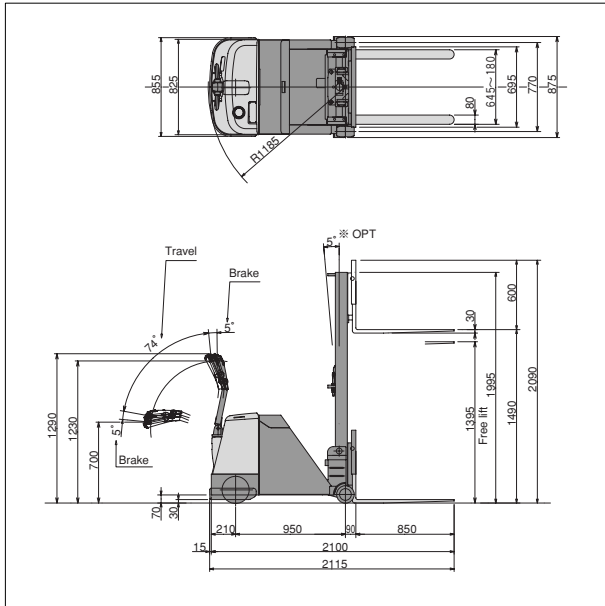

Capacity		Unit	LC 400mm	700
Travel speed	Laden	km/h	4.5	
	Unladen	km/h	4.5	
Lifting speed	Laden	mm/s	115	
	Unladen	mm/s	190	
Motor	Traction	kW	1.0	
	Hydraulic	kW	1.5	
	Power steering	kW	0.15	
Control system	Traction		Invertor	
	Hydraulic		Contactor	
	Power steering		Chopper	
Battery (24V)	STD	Ah/5HR	165 (Weight : 140kg)	
	OPT	Ah/5HR	EB 100	
Charger	Built-in	kVA	1.6 (1φ 100V)	
	Stationary	kVA	1.2 (3φ 200V)	
Wheel			Solid	
Load	Urethane		φ152×90 2pcs.	
Drive	STD	Rubber	φ235×120 1pc.	
	OPT(CS)	Rubber lug		
Service weight	W/Battery and built-in charger	kg	940	
	W/Stationary charger	kg	-15	

FBD7-70-□□□

(Two stage mast)

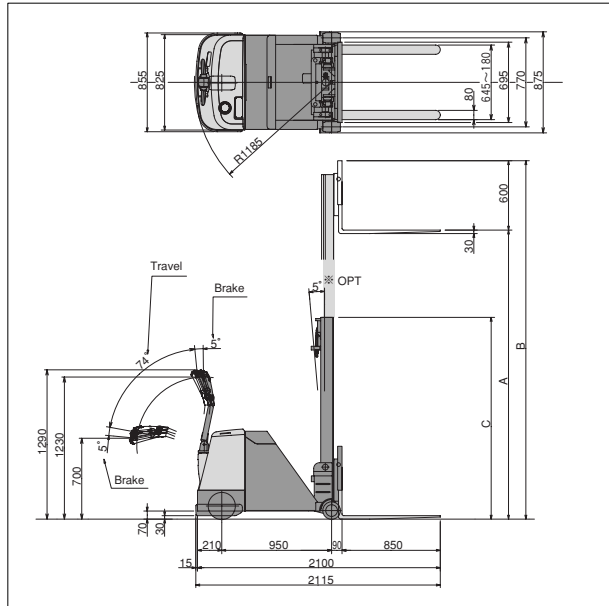

Capacity		Unit	LC 400mm	W
Travel speed	Laden	km/h	4.5	
	Unladen	km/h	4.5	
Lifting speed	Laden	mm/s	115	
	Unladen	mm/s	190	
Motor	Traction	kW	1.0	
	Hydraulic	kW	1.5	
	Power steering	kW	0.15	
Control system	Traction		Invertor	
	Hydraulic		Contactor	
	Power steering		Chopper	
Battery (24V)	STD	Ah/5HR	165 (Weight : 140kg)	
	OPT	Ah/5HR	EB 100	
Charger	Built-in	kVA	1.6 (1φ 100V)	
	Stationary	kVA	1.2 (3φ 200V)	
Wheel			Solid	
Load	Urethane		φ152×90 2pcs.	
Drive	STD	Rubber	φ235×120 1pc.	
	OPT(CS)	Rubber lug		
Service weight	W/Battery and built-in charger	kg	G	
	W/Stationary charger	kg	-15	

Capacity Chart (Single mast)

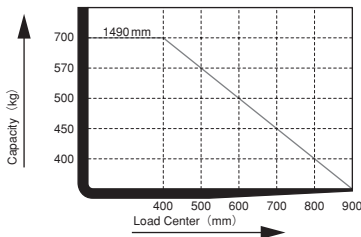

Mast	Capacity	Lift height	Overall height	Overall height	Service weight
★★★	W kg	A mm	Mast extended B mm	Mast lowered C mm	G kg
200	700	1990	2590	1495	980
230		2290	2890	1645	990
250	650	2490	3090	1745	1000
270		2690	3290	1845	1005
300	600	2990	3590	1995	1015
330	550	3290	3890	2145	1030
350	500	3490	4090	2245	1035

Capacity Chart (Two stage mast)

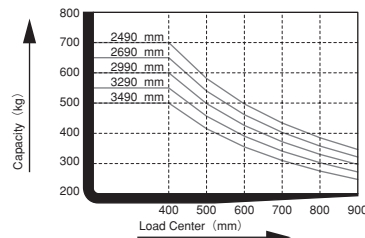

FBD9-70-150

(Single mast)

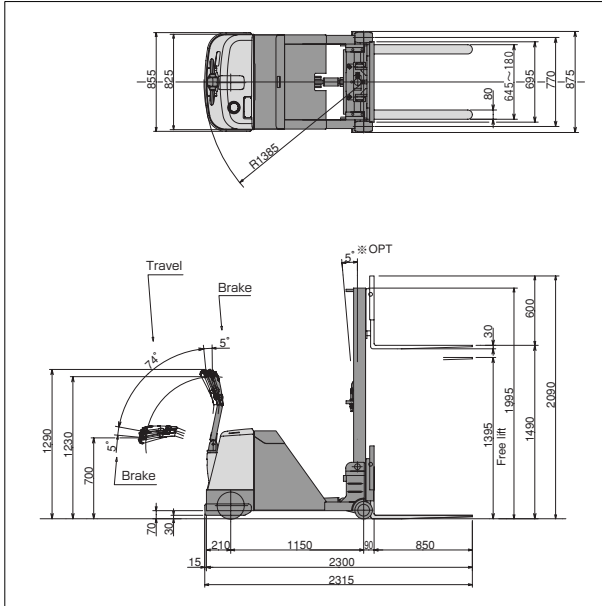

Capacity		Unit	kg	LC 400mm 900
Travel speed	Laden	km/h	4.5	
	Unladen	km/h	4.5	
Lifting speed	Laden	mm/s	105	
	Unladen	mm/s	190	
Motor	Traction	kW	1.0	
	Hydraulic	kW	1.5	
	Power steering	kW	0.15	
Control system	Traction		Invertor	
	Hydraulic		Contactor	
	Power steering		Chopper	
Battery (24V)	STD	Ah/5HR	165 (Weight : 140kg)	
	OPT	Ah/5HR	EB 100	
Charger	Built-in	kVA	1.6 (1φ 100V)	
	Stationary	kVA	1.2 (3φ 200V)	
Wheel			Solid	
Load	Urethane		φ152×90	2pcs.
Drive	STD	Rubber		
	OPT(CS)	Rubber lug		
Service weight W/Std. batt. and built-in charger		kg	1060	
W/Opt. battery		kg	-70	
W/Stationary charger		kg	-15	

FBD9-70-□□□

(Two stage mast)

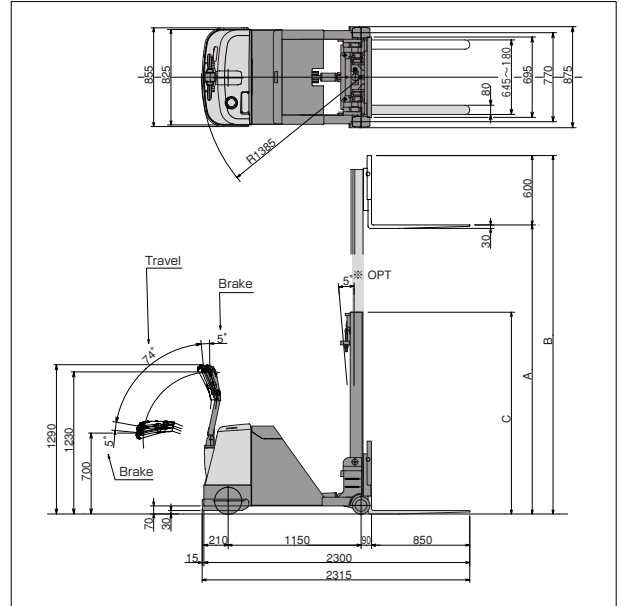

Capacity		Unit	kg	LC 400mm W
Travel speed	Laden	km/h	4.5	
	Unladen	km/h	4.5	
Lifting speed	Laden	mm/s	105	
	Unladen	mm/s	190	
Motor	Traction	kW	1.0	
	Hydraulic	kW	1.5	
	Power steering	kW	0.15	
Control system	Traction		Invertor	
	Hydraulic		Contactor	
	Power steering		Chopper	
Battery (24V)	STD	Ah/5HR	165 (Weight : 140kg)	
	OPT	Ah/5HR	EB 100	
Charger	Built-in	kVA	1.6 (1φ 100V)	
	Stationary	kVA	1.2 (3φ 200V)	
Wheel			Solid	
Load	Urethane		φ152×90	2pcs.
Drive	STD	Rubber		
	OPT(CS)	Rubber lug		
Service weight W/Std. batt. and built-in charger		kg	G	
W/Opt. battery		kg	-70	
W/Stationary charger		kg	-15	

Capacity Chart (Single mast)

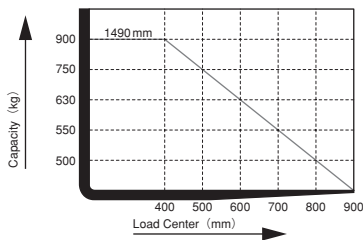

Mast ★★★	Capacity W kg	Lift height A mm	Overall height	Overall height	Service weight G kg
			Mast extended B mm	Mast lowered C mm	
200	900	1990	2590	1495	1110
230		2290	2890	1645	1120
250		2490	3090	1745	1130
270	830	2690	3290	1845	1135
300	770	2990	3590	1995	1145
330	700	3290	3890	2145	1155
350	630	3490	4090	2245	1165

Capacity Chart (Two stage mast)

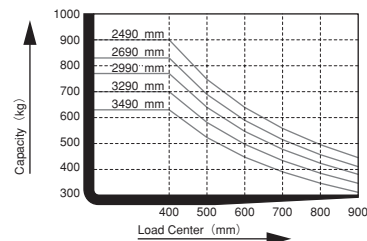

NICHYU WALKIE HIGH LIFT TRUCKS

Capacity: 1000kg

FBD10-70-150

(Single mast)

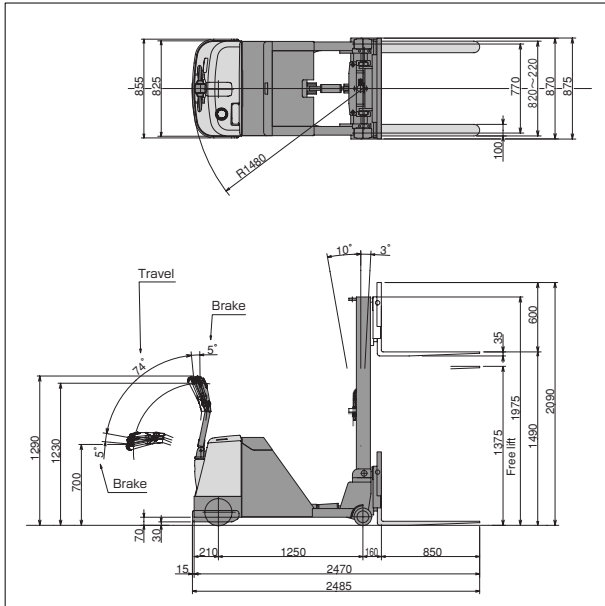

Capacity			Unit	kg	LC 500mm	1000
Travel speed	Laden	km/h			4.5	
	Unladen	km/h			4.5	
Lifting speed	Laden	mm/s			100	
	Unladen	mm/s			190	
Motor	Traction	kW			1.0	
	Hydraulic	kW			1.5	
	Power steering	kW			0.15	
Control system	Traction				Inverter	
	Hydraulic				Contact	
	Power steering				Chopper	
Battery (24V)		Ah/5HR			165 (Weight : 140kg)	
Charger	Built-in	kVA			1.6 (1φ 100V)	
	Stationary	kVA			1.2 (3φ 200V)	
Wheel					Solid	
Load	Urethane				φ152×90	2pcs.
Drive	STD	Rubber			φ235×120	1pc.
	OPT(CS)	Rubber lug				
Service weight W/Std. batt. and built-in charger			kg		1350	
W/Stationary charger			kg		-15	

FBD10-70-□□□

(Two stage mast)

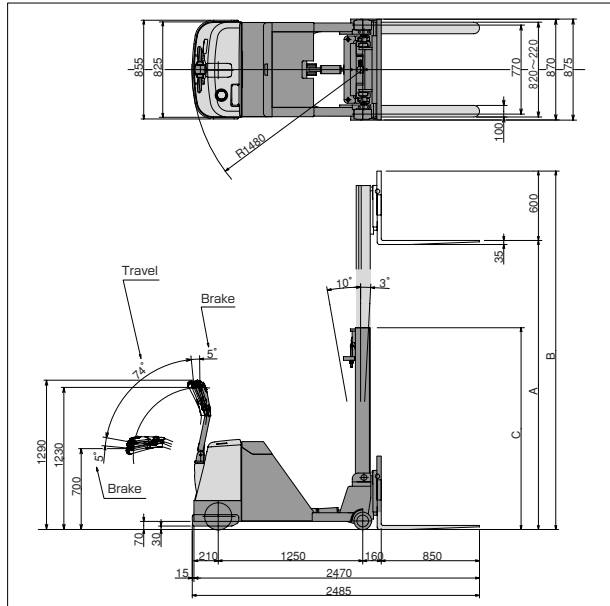

Capacity			Unit	kg	LC 500mm	W
Travel speed	Laden	km/h			4.5	
	Unladen	km/h			4.5	
Lifting speed	Laden	mm/s			95	
	Unladen	mm/s			180	
Motor	Traction	kW			1.0	
	Hydraulic	kW			1.5	
	Power steering	kW			0.15	
Control system	Traction				Inverter	
	Hydraulic				Contact	
	Power steering				Chopper	
Battery (24V)		Ah/5HR			165 (Weight : 140kg)	
Charger	Built-in	kVA			1.6 (1φ 100V)	
	Stationary	kVA			1.2 (3φ 200V)	
Wheel					Solid	
Load	Urethane				φ152×90	2pcs.
Drive	STD	Rubber			φ235×120	1pc.
	OPT(CS)	Rubber lug				
Service weight W/Std. batt. and built-in charger			kg		G	
W/Stationary charger			kg		-15	

Capacity Chart (Single mast)

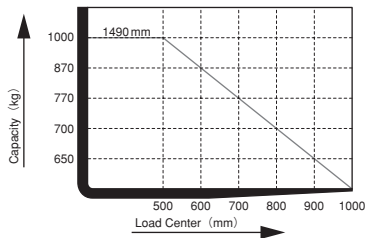

Mast	Capacity	Lift height	Overall height	Overall height	Service weight
★★★	W kg	A mm	Mast extended B mm	Mast lowered C mm	G kg
200	1000	1990	2590	1495	1420
230		2290	2890	1645	1435
250		2490	3090	1745	1445
270	950	2690	3290	1845	1455
300	900	2990	3590	1995	1470
330	850	3290	3890	2145	1485
350	800	3490	4090	2245	1495

Capacity Chart (Two stage mast)

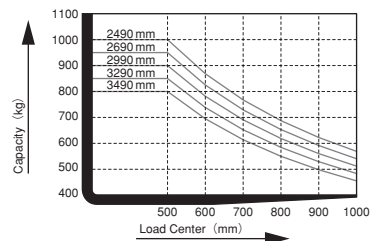

NICHYU WALKIE HIGH LIFT TRUCKS

Capacity : 700kg

SBW7-70-150

(Single mast)

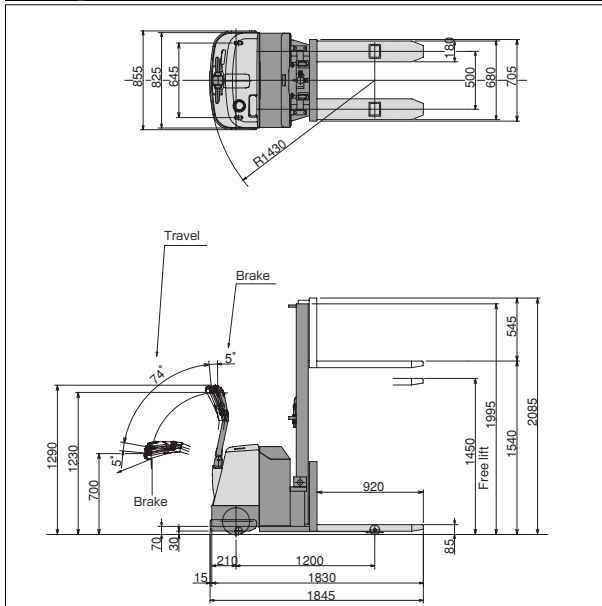

Capacity		kg	LC 400mm 700
Travel speed	Laden	km/h	4.5
	Unladen	km/h	4.5
Lifting speed	Laden	mm/s	115
	Unladen	mm/s	190
Motor	Traction	kW	1.0
	Hydraulic	kW	1.5
	Power steering	kW	0.15
Control system	Traction		Inverter
	Hydraulic		Contactors
	Power steering		Chopper
Battery (24V)	STD	Ah/5HR	165 (Weight : 140kg)
	OPT	Ah/5HR	EB 100
Charger	Built-in	kVA	1.6 (1φ 100V)
	Stationary	kVA	1.2 (3φ 200V)
Wheel			Solid
Load	Urethane		φ83×100 2pcs.
Drive	STD	Rubber	φ235×120 1pc.
	OPT(CS)	Rubber lug	
Caster	Urethane		φ65×30 2pcs.
Service weight W/Std. batt. and built-in charger	kg		715
W/Opt. battery	kg		-70
W/Stationary charger	kg		-70

SBW7-70-□□□

(Two stage mast)

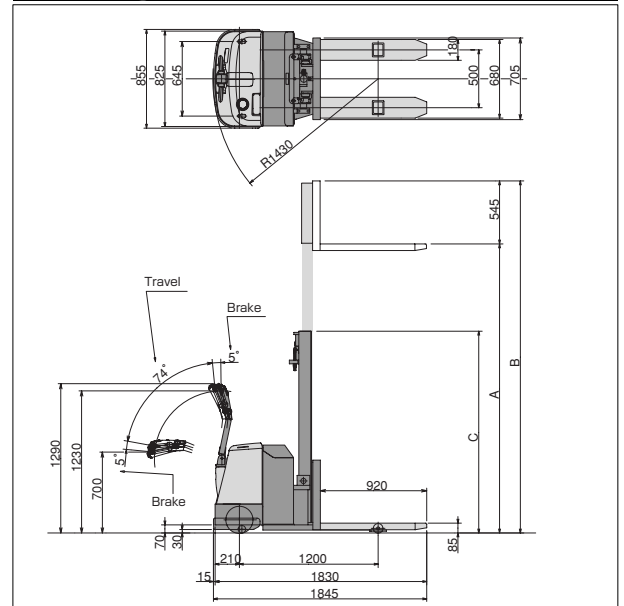

Capacity		kg	LC 400mm W
Travel speed	Laden	km/h	4.5
	Unladen	km/h	4.5
Lifting speed	Laden	mm/s	115
	Unladen	mm/s	190
Motor	Traction	kW	1.0
	Hydraulic	kW	1.5
	Power steering	kW	0.15
Control system	Traction		Inverter
	Hydraulic		Contactors
	Power steering		Chopper
Battery (24V)	STD	Ah/5HR	165 (Weight : 140kg)
	OPT	Ah/5HR	EB 100
Charger	Built-in	kVA	1.6 (1φ 100V)
	Stationary	kVA	1.2 (3φ 200V)
Wheel			Solid
Load	Urethane		φ83×100 2pcs.
Drive	STD	Rubber	φ235×120 1pc.
	OPT(CS)	Rubber lug	
Caster	Urethane		φ65×30 2pcs.
Service weight W/Std. batt. and built-in charger	kg		G
W/Opt. battery	kg		-70
W/Stationary charger	kg		-70

Capacity Chart (Single mast)

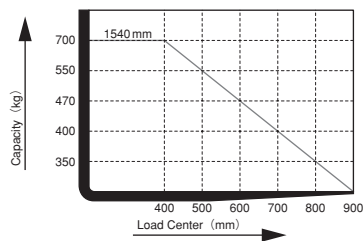

Mast	Capacity	Lift height	Overall height Mast extended	Overall height Mast lowered	Service weight
★★★	W kg	A mm	B mm	C mm	G kg
200	700	2040	2585	1495	760
230		2340	2885	1645	770
250		2540	3085	1745	780

Capacity Chart (Two stage mast)

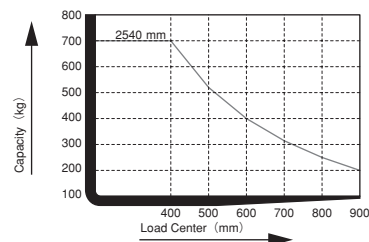

NICHYU WALKIE HIGH LIFT TRUCKS

Capacity : 900kg

SBW9-70-150

(Single mast)

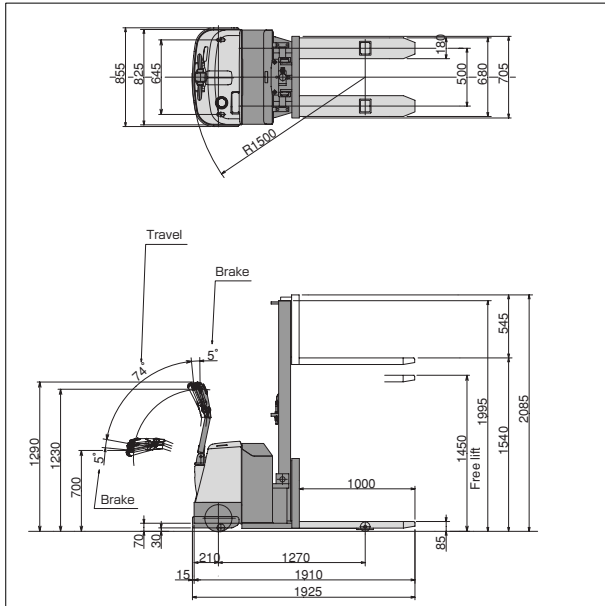

Capacity	Unit		kg	LC 400mm 900
Travel speed	Laden	km/h	4.5	
	Unladen	km/h	4.5	
Lifting speed	Laden	mm/s	105	
	Unladen	mm/s	190	
Motor	Traction	kW	1.0	
	Hydraulic	kW	1.5	
	Power steering	kW	0.15	
Control system	Traction		Invertor	
	Hydraulic		Contactor	
	Power steering		Chopper	
Battery (24V)	STD	Ah/5HR	165 (Weight : 140kg)	
	OPT	Ah/5HR	EB 100	
Charger	Built-in	kVA	1.6 (1φ 100V)	
	Stationary	kVA	1.2 (3φ 200V)	
Wheel			Solid	
Load	Urethane		φ83×100 2pcs.	
Drive	STD	Rubber	φ235×120 1pc	
	OPT(CS)	Rubber lug		
Caster	Urethane		φ65×30 2pcs.	
Service weight W/Std. batt. and built-in charger	kg	720		
W/Opt. battery	kg	-70		
W/Stationary charger	kg	-15		

SBW9-70-□□□□

(Two stage mast)

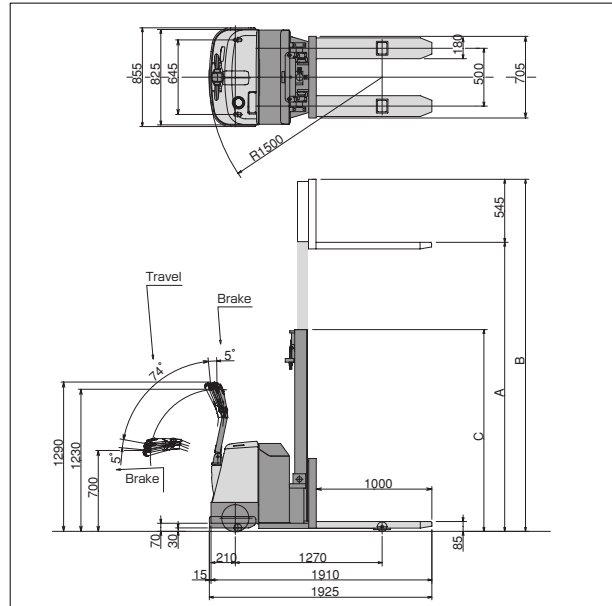

Capacity	Unit		kg	LC 400mm W
Travel speed	Laden	km/h	4.5	
	Unladen	km/h	4.5	
Lifting speed	Laden	mm/s	105	
	Unladen	mm/s	190	
Motor	Traction	kW	1.0	
	Hydraulic	kW	1.5	
	Power steering	kW	0.15	
Control system	Traction		Invertor	
	Hydraulic		Contactor	
	Power steering		Chopper	
Battery (24V)	STD	Ah/5HR	165 (Weight : 140kg)	
	OPT	Ah/5HR	EB 100	
Charger	Built-in	kVA	1.6 (1φ 100V)	
	Stationary	kVA	1.2 (3φ 200V)	
Wheel			Solid	
Load	Urethane		φ83×100 2pcs.	
Drive	STD	Rubber	φ235×120 1pc.	
	OPT(CS)	Rubber lug		
Caster	Urethane		φ65×30 2pcs.	
Service weight W/Std. batt. and built-in charger	kg	G		
W/Opt. battery	kg	-70		
W/Stationary charger	kg	-15		

Capacity Chart (Single mast)

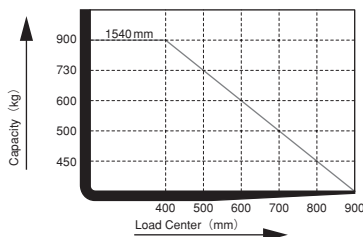

Mast	Capacity	Lift height	Overall height	Overall height	Service weight
★★★	W kg	A mm	Mast extended B mm	Mast lowered C mm	G kg
200	900	2040	2585	1495	765
230		2340	2885	1645	775
250		2540	3085	1745	785

Capacity Chart (Two stage mast)

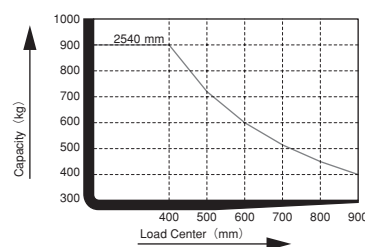

NICHYU WALKIE HIGH LIFT TRUCKS

Capacity : 900kg

SBWW9-70-150 ※Double face pallets specification

(Single mast)

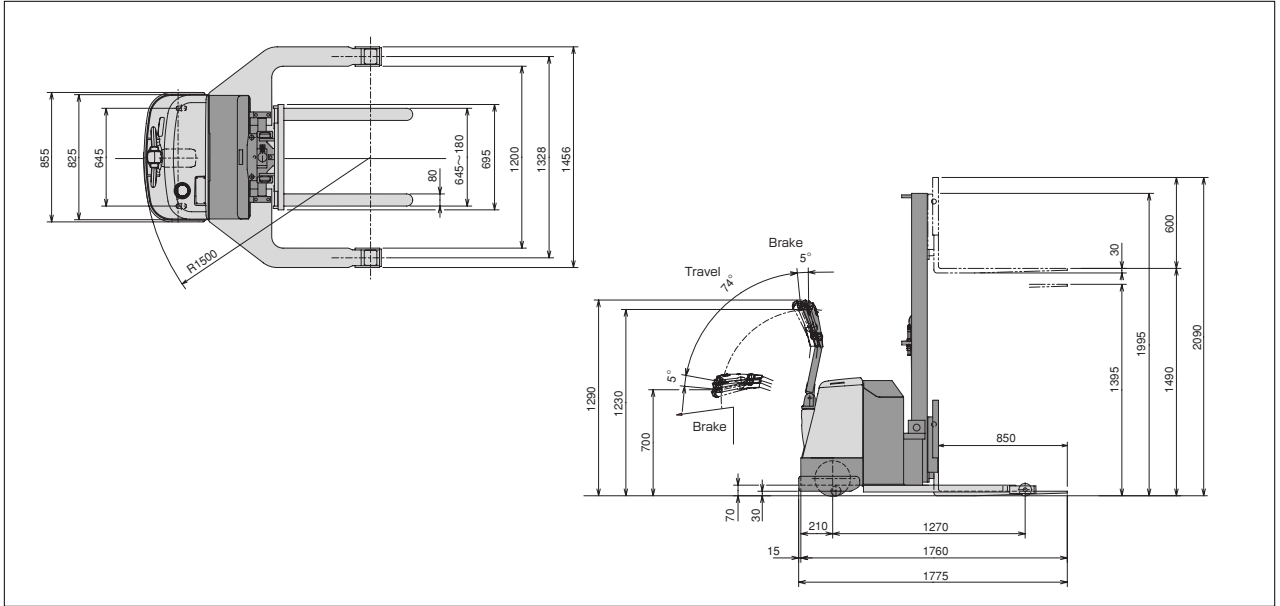

		Unit	
Capacity		kg	LC400mm 900
Travel speed	Laden	km/h	4.5
	Unladen	km/h	4.5
Lifting speed	Laden	mm/s	105
	Unladen	mm/s	190
Motor	Traction	kW	1.0
	Hydraulic	kW	1.5
	Power steering	kW	0.15
Control system	Traction		Invertor
	Hydraulic		Contactora
	Power steering		Chopper
Battery (24V)	STD	Ah/5HR	165 (Weight: 140kg)
Charger	Built-in	kVA	1.6 (1φ 100V)
	Stationary	kVA	1.2 (3φ 200V)
Wheel			Solid
Load	Urethane		φ83x100 2pcs.
Drive	STD	Rubber	φ235x120 1pc.
	OPT(CS)	Rubber lug	
Caster	Urethane		φ65x30 2pcs.
Service weight W/ battery and built-in charger		kg	820
W/Stationary charger		kg	-15

Capacity Chart (Single mast)

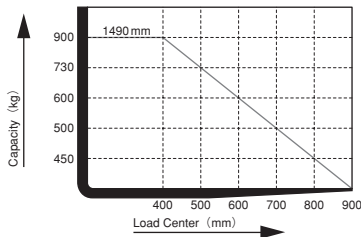

ECO-LOGISTICS since 1937

NICHYU

NIPPON YUSOKI CO., LTD.

1-1, 2-chome, Higashikotari, Nagaokakyo-shi, Kyoto 617-8585 Japan
Phone: +81-75-956-8622 Fax: +81-75-955-0480
URL: <http://www.nichiyunet.co.jp/>



ISO 9001
ISO 14001
JQA-QM3889
JQA-EM4909

All specifications are confirmed based on manufacturer's terms and conditions.
All specifications are subject to change without notice in the interest of continued improvement or modifications.

Cat. No. OSD070-1 3000/0602(SP) Printed in Japan